



1/11

AF

TRANSMITTAL OF APPEAL BRIEF (Large Entity)

Docket No. VAS.0002US

In Re Application Of: Karl-Lutz Lauterjung

Application No.	Filing Date	Examiner	Customer No.	Group Art Unit	Confirmation No.
08/878,908	June 19, 1997	Paul B. Prebilic	21906	3774	8837

Invention: Prosthetic Repair of Body Passages

COMMISSIONER FOR PATENTS:

Transmitted herewith is the Appeal Brief in this application, with respect to the Notice of Appeal filed on: April 7, 2008

The fee for filing this Appeal Brief is: \$510.00

- A check in the amount of the fee is enclosed.
- The Director has already been authorized to charge fees in this application to a Deposit Account.
- The Director is hereby authorized to charge any fees which may be required, or credit any overpayment to Deposit Account No. 20-1504. I have enclosed a duplicate copy of this sheet.
- Payment by credit card. Form PTO-2038 is attached.

WARNING: Information on this form may become public. Credit card information should not be included on this form. Provide credit card information and authorization on PTO-2038.

  
Signature

Dated: June 9, 2008

Timothy N. Trop, Reg. No. 28,994  
TROP, PRUNER & HU, P.C.  
1616 S. Voss Road, Suite 750  
Houston, TX 77057  
713/468-8880 [Phone]  
713/468-8883 [Fax]

I hereby certify that this correspondence is being deposited with the United States Postal Service with sufficient postage as first class mail in an envelope addressed to "Commissioner for Patents, P.O. Box 1450, Alexandria, VA 22313-1450" [37 CFR 1.8(a)] on

June 9, 2008

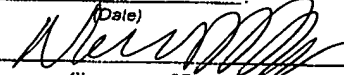
  
(Date)

Signature of Person Mailing Correspondence

Nancy Meshkoff

Typed or Printed Name of Person Mailing Correspondence

cc:



THE UNITED STATES PATENT AND TRADEMARK OFFICE

Applicant:	Karl-Lutz Lauterjung	§	Group Art Unit:	3738
		§		
Serial No.:	08/878,908	§	Examiner:	Paul B. Prebilic
		§		
Filed:	June 19, 1997	§		
		§		
For:	Prosthetic Repair of Body Passages	§	Atty. Dkt. No.:	VAS.0002US
		§		
Customer No.:	21906	§	Confirmation No.:	8837

Mail Stop **Appeal Brief-Patents**  
 Commissioner for Patents  
 P.O. Box 1450  
 Alexandria, VA 22313-1450

**APPEAL BRIEF**

06/13/2008 HVUONG1 00000020 08878908  
 01 FC:1402 510.00 OP

Date of Deposit: June 9, 2008  
 I hereby certify under 37 CFR 1.8(a) that this correspondence is being deposited with the United States Postal Service as **first class mail** with sufficient postage on the date indicated above and is addressed to the Commissioner for Patents, P.O. Box 1450, Alexandria, VA 22313-1450.  
 \_\_\_\_\_  
 Nancy Meshkoff

**TABLE OF CONTENTS**

REAL PARTY IN INTEREST..... 3

RELATED APPEALS AND INTERFERENCES..... 4

STATUS OF CLAIMS ..... 5

STATUS OF AMENDMENTS ..... 6

SUMMARY OF CLAIMED SUBJECT MATTER ..... 7

GROUND OF REJECTION TO BE REVIEWED ON APPEAL ..... 15

ARGUMENT..... 16

CLAIMS APPENDIX..... 19

EVIDENCE APPENDIX..... 24

RELATED PROCEEDINGS APPENDIX ..... 25

**REAL PARTY IN INTEREST**

The real party in interest is the assignee Vascutek Limited.

**RELATED APPEALS AND INTERFERENCES**

Appeal No. 2001-1407, Decision mailed September 13, 2002, in the present case.

Appeal No. 2003-1502, Decision mailed September 29, 2003, in 09/365,860, now US Patent No. 6,740,111, a continuation of the present case.

## **STATUS OF CLAIMS**

Claims 1-31 (Canceled).

Claim 32 (Objected to, Provisionally Rejected).

Claims 33-64 (Canceled).

Claims 65-73 (Rejected).

Claim 74 (Canceled).

Claims 75-79 (Rejected).

Claim 80 (Canceled).

Claims 81-82 (Rejected).

Claim 32 is objected to and provisionally rejected; claims 65-73, 75-79, and 81-82 are rejected and are the subject of this Appeal Brief.

**STATUS OF AMENDMENTS**

No Reply to Final Rejection was submitted. All amendments have therefore been entered.

## SUMMARY OF CLAIMED SUBJECT MATTER

In the following discussion, the independent claims are read on one of many possible embodiments without limiting the claims:

65. A prosthesis comprising:  
a tubular graft (Fig. 3, 42) having a length, a pair of free ends opposed along the length of said graft, and a first diameter (Fig. 3,  $D_p$ ) perpendicular to said length (Spec. at p. 9:24-31); and

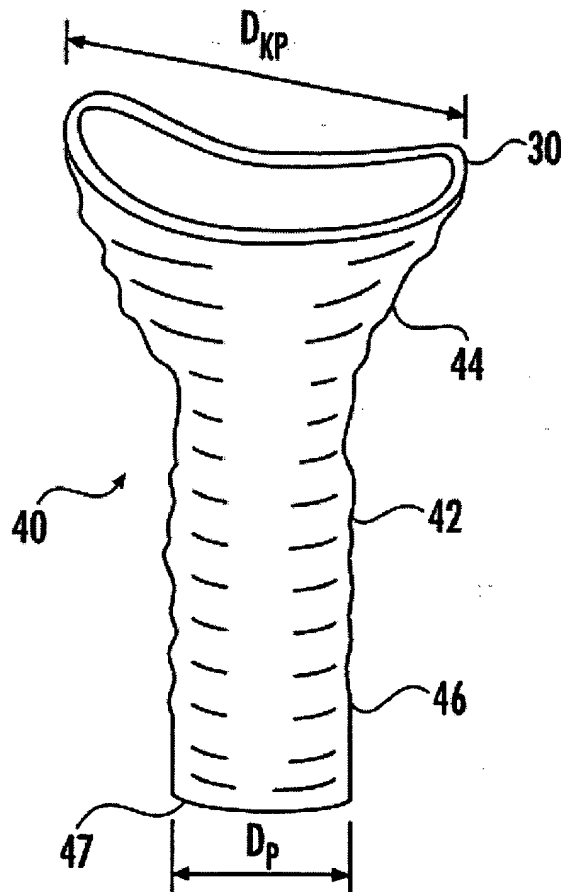
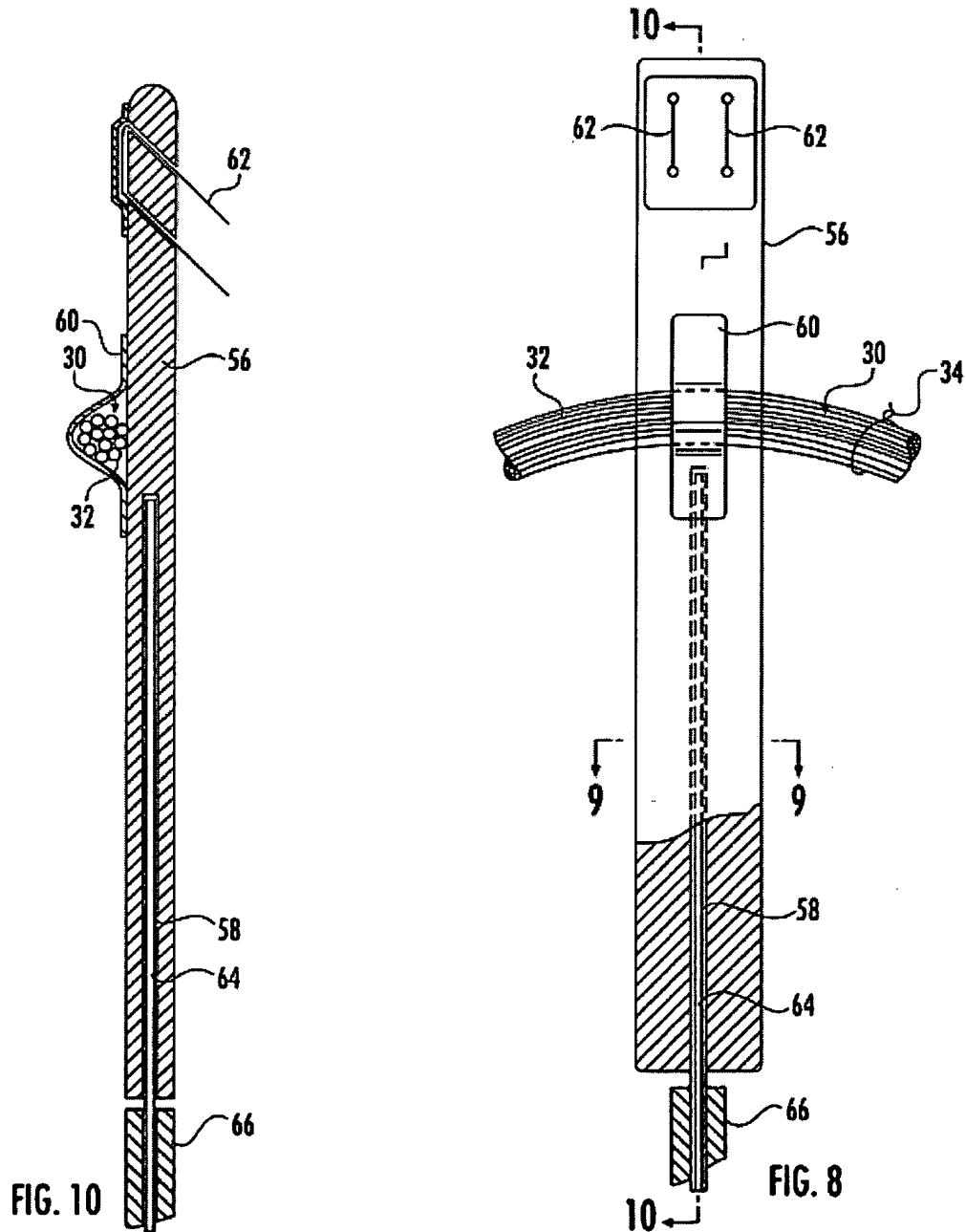

FIG. 3



a deformable ring (Fig. 3, 30) having a second diameter (Fig. 3,  $D_{KP}$ ), said second diameter parallel to said first diameter, the ring formed of a bundle of windings (Fig. 10, 32) of a strand of resilient metal wire (Spec. at p. 7:6-10), said windings connected together to form the ring (Fig. 1, 34; Spec. at p. 7:10-13), the windings wrapped one over the other such that a particular winding has substantially continuous contact with one or more other windings for a complete turn of the particular winding (Figs. 10, 8; Spec. at p. 7:10-13),



each winding being a closed loop of a portion of said metal wire (Fig. 1; Spec. at p. 7:10-13), each loop having substantially said second diameter (Fig. 1,  $D_K$ ), each loop lying substantially in a plane (Fig. 1), the planes of said loops being parallel (Spec. at p. 9:1-5) and substantially coplanar (Figs. 1, 10), the second diameter of said ring (Fig. 3,  $D_{KP}$ ) greater than the first diameter (Fig. 3,  $D_P$ ) of the tubular graft (Spec. at p. 11:20-25), said ring secured to said graft adjacent one of said free ends (Fig. 3; Spec. at p. 9:24-27), each of said loops constituting a length of a portion of said metal wire such that the loop wraps back upon itself (Spec. at p. 7:10-13), said loops defining a flattened helical coil (Spec. at p. 7:20-22) wherein said loops that define the coil touch adjacent loops of the coil (Fig. 10).

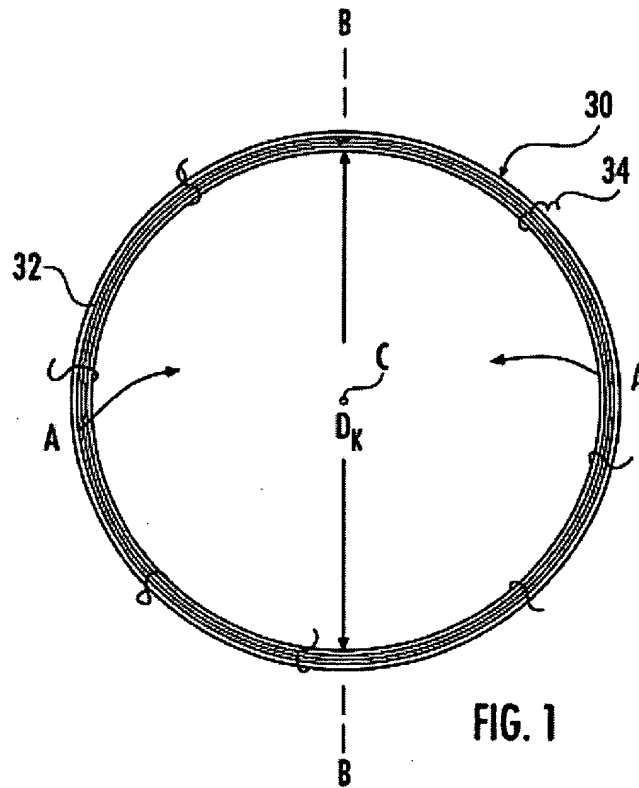

66. A prosthesis comprising:  
 a tubular graft (Fig. 3, 42) having a length, a pair of free ends opposed along the length of said graft, and a first diameter (Fig. 3,  $D_P$ ) perpendicular to said length (Spec. at p. 9:24-31); and  
 a bundle of radially overlapping windings (Fig. 10, 32) formed of a single strand

of resilient metal wire (Spec. at p. 7:6-10), a particular winding having substantially continuous contact with one or more other windings throughout a complete turn of said particular winding (Figs. 8, 10; Spec. at p. 7:10-13), a second diameter (Fig. 1,  $D_K$ ) of said bundle of windings greater than the first diameter (Fig. 3,  $D_P$ ) of said graft (Spec. at p. 11:20-25), said windings being concentric with said tubular graft and located adjacent one of said free ends (Fig. 3), said bundle being a helical coil of a plurality of closed loops (Spec. at p. 7:10-13), each loop being a portion of a length of said wire wrapped upon itself (Spec. at p. 7:10-13), said loops being collapsed along an axis (Fig. 1, C) of said coil to form a flattened helical coil (Fig. 10), said axis extending generally transverse to the diameters (Fig. 1,  $D_K$ ) of said loops, each of said loops having substantially the same diameter (Fig. 1) and each of said loops contacting at least one adjacent loop of said helical coil (Fig. 10; Spec. at p. 7:20-22), said second diameter ( $D_K$ ) being parallel to said first diameter ( $D_P$ ).

67. A prosthesis comprising:

a tubular graft (Fig. 3, 42) having a length, a pair of free ends opposed along the length of said graft, and a first diameter (Fig. 3,  $D_P$ ) perpendicular to said length (Spec. at p. 9:24-31); and

a ring (Fig. 3, 30) located adjacent one of said free ends and coaxial therewith, said ring having a second diameter (Fig. 3,  $D_{KP}$ ) and comprising windings formed of a single strand (Fig. 10, 32) of resilient metal wire (Spec. at p. 7:6-10), the second diameter of the ring substantially the same as a diameter of at least one of the windings, the windings wound one over the other and connected to form a bundle (Fig. 10, 32), the bundle of said windings having a substantially circular cross-section (Fig. 10), each of said windings being a closed loop of a portion of said metal wire (Fig. 1; Spec. at p. 7:10-13), said loop being substantially circular, having substantially the same diameter as said ring (Fig. 1, 10), contacting at least one adjacent loop (Fig. 10), and turned back on itself to form a circular loop (Figs. 8, 10; Spec. at p. 7:10-13), said second diameter parallel to said first diameter (Fig. 10), said ring comprising said windings and said graft being coaxial (Fig. 3).

70. A prosthesis for being positioned in a blood vessel comprising:  
 a graft (Fig. 3, 42); and  
 an annular resilient element (Fig. 3, 30) attached to said graft, said element comprising a bundle of concentric, radially overlapping windings (Fig. 10, 32) formed of a strand of resilient wire (Spec. at p. 7:6-10), each winding in the form of a closed loop of a portion of the length of said resilient wire, each of said loops wrapping back upon itself, said loops collectively defining a flattened helical coil (Spec. at p. 7:20-22) defining said annular resilient element (Fig. 1, 34; Spec. at p. 7:10-13), a diameter of the annular resilient element (Fig. 1,  $D_K$ ) substantially the same as a diameter of at least one of said windings, said annular resilient element adapted to be folded about its diametric axis to assume a smaller cross-sectional configuration (Fig. 2) and adapted to engage the inside of a body passage (Fig. 18, 54; Spec. at p. 17:18-20) in said folded configuration (Fig. 5), and when said folded annular resilient element is engaged with said body passage, said graft to extend along a length of a first blood vessel (Fig. 18, 108), a part of said graft adapted to be positioned past a point of an intersection of said first blood vessel and a second blood vessel (Fig. 18, 10; Spec. at p. 7:14-18) so as not to occlude an opening to permit communication of said intersection, said folded annular resilient element defining a C-shaped configuration (Spec. at p. 18:32-19:8), said graft and said element being coaxial (Fig. 3).

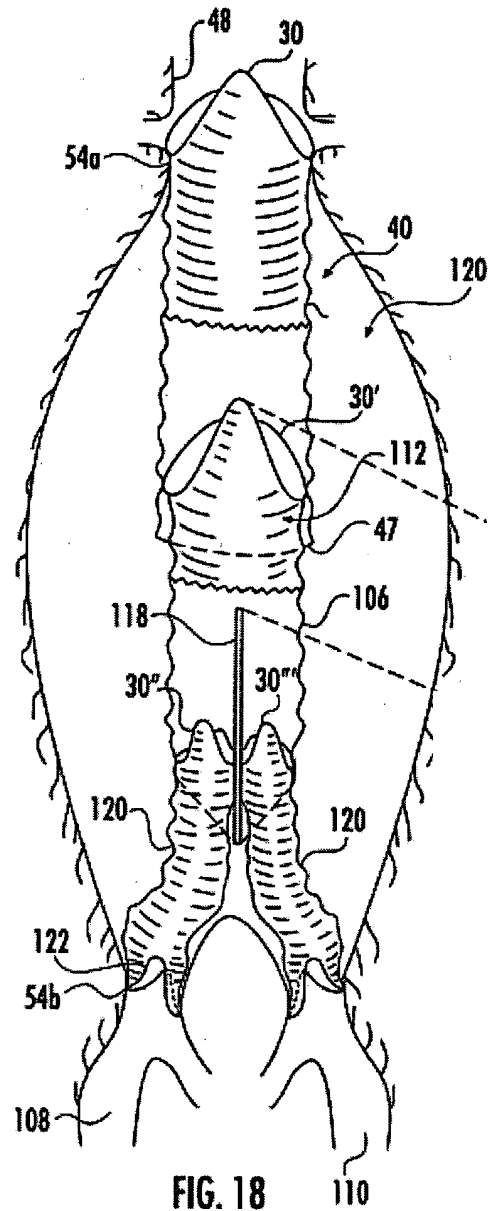

75. A prosthesis for being positioned in a blood vessel comprising:  
an annular resilient element (Fig. 3, 30), said element comprising a bundle of concentric, radially overlapping windings (Fig. 10, 32) formed of a strand of resilient metal wire (Spec. at p. 7:6-10), one of said windings in contact with another of said windings, said contact for a full turn of said one of said windings (Figs. 8, 10; Spec. at p. 7:10-13) and said contact not limited to contact with the same another of said windings (Figs. 8, 10; Spec. at p. 7:10-13), a diameter of the annular element (Fig. 1,  $D_K$ ) substantially the same as a diameter of at least one of said windings, said annular element adapted to be folded about its diametric axis to assume a smaller cross-sectional configuration (Fig. 2), said folded element adapted to be situated in said blood vessel (Fig. 18, 54) with an arcuate portion of said folded element engaged with said blood vessel (Spec. at p. 18:32-19:8);

said annular resilient element being a helical coil (Spec. at p. 7:20-22) made up of the plurality of parallel loops (Spec. at p. 9:1-5) having substantially the same diameter and having a common axis (Fig. 1, 10), said loops being flattened upon one another so that adjacent loops are touching, substantially coplanar (Fig. 1), and parallel (Fig. 10); and

a graft (Fig. 3, 42), said element attached to an end of said graft, a tip (Fig. 2, A) of each fold of said folded element to contact the graft, said graft having a length parallel to the common axis of said loop (Spec. at p. 8:18-21).

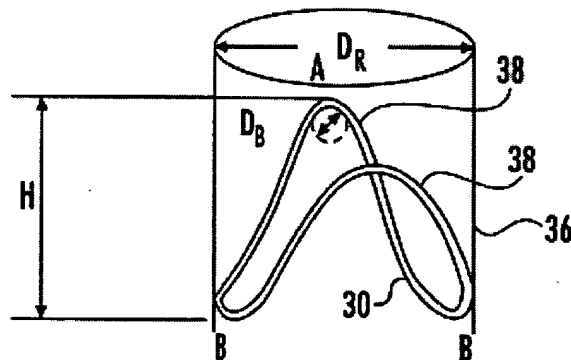

FIG. 2

81. A prosthesis for being positioned in a blood vessel comprising:  
 a tubular graft (Fig. 3, 42) having a length; and  
 an annular resilient element (Fig. 3, 30) attached to said graft, said element comprising a bundle of concentric, windings (Fig. 10, 32) formed of a strand of resilient metal wire (Spec. at p. 7:6-10), said windings overlapping along radii of said annular resilient element, a diameter of the annular element (Fig. 1,  $D_K$ ) substantially the same as a diameter of at least one of said windings, said annular element adapted to be folded about its diametric axis to assume a smaller cross-sectional configuration (Fig. 5; Spec. at p. 9:17-19), said graft adapted to be positioned within a first blood vessel (Fig. 5, 55) proximate to a second blood vessel (Fig. 5, 52) such that the diametric axis of said element is proximate to an intersection of said first blood vessel and said second blood vessel and a part of said graft (Fig. 5, 38) is to extend past said intersection so as not to occlude an opening and to permit communication with said intersection (Spec. at p. 11:1-9), only a part of both said graft and said annular resilient element (Fig. 2, A) to engage a portion of said first blood vessel located past said second blood vessel, said windings formed of a plurality of circular loops formed of a portion of said wire turned back on itself (Spec. at p. 7:10-13) such that a plurality of adjacent loops are connected together to form a helical coil (Spec. at p. 7:20-22), said helical coil being flattened such that each of said loops touch another loop and each of said loops are substantially coplanar with each of said other loops (Fig. 10) and said loops having a common central axis (Fig. 1, C), said element having a central axis (Fig. 1, C) parallel to the length of said graft.

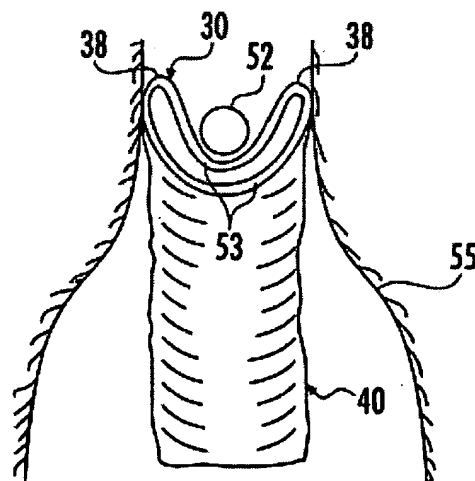

FIG. 5

82. A prosthesis comprising:  
a tubular graft (Fig. 3, 42) having a length; and  
a deformable, annular, resilient element (Fig. 3, 30) located near one end of said graft, said element comprising a bundle of windings (Fig. 10, 32) formed of a strand of wire (Spec. at p. 7:6-10), said windings overlapping along radii of said annular resilient element, said bundle substantially circular in cross-section (Fig. 10), wherein said cross-section can be taken at any point on a circumference of said element, a diameter of said element (Fig. 1,  $D_K$ ) substantially the same as a diameter of at least one of said windings, said element adapted to be folded around its diametric axis and to resiliently engage a first human blood vessel in a C-shaped deformed configuration (Fig. 5; Spec. at p. 9:17-19), a part of said C-shaped deformed element to resiliently engage said first human blood vessel past a point of intersection of said first blood vessel and a second blood vessel to permit communication of said intersection (Spec. at p. 11:1-9), each of said windings being a loop of a portion of a length of wire turned back on itself such that a plurality of adjacent loops are connected together defining a helical coil (Spec. at p. 7:20-22), said helical coil being flattened such that each of said loops touch another loop and each of said loops is substantially coplanar with each of said other loops (Figs. 1, 10) and said loops have a common central axis (Fig. 1, C), said element having a central axis parallel to the length of said graft.

At this point, no issue has been raised that would suggest that the words in the claims have any meaning other than their ordinary meanings. Nothing in this section should be taken as an indication that any claim term has a meaning other than its ordinary meaning.

**GROUND OF REJECTION TO BE REVIEWED ON APPEAL**

- A. Whether claims 65-73, 75-79, and 81-82 fail to comply with the written description requirement under 35 U.S.C. § 112, first paragraph.**
  
- B. Whether claims 65-73, 75-79, and 81-82 are indefinite under 35 U.S.C. § 112, second paragraph as failing to particularly point out and distinctly claim the subject matter of the invention.**



## ARGUMENT

### **A. Do claims 65-73, 75-79, and 81-82 fail to comply with the written description requirement under 35 U.S.C. § 112, first paragraph?**

In order to satisfy the written description requirement, the disclosure as originally filed does not have to provide *in haec verba* support for the claimed subject matter at issue. See *Fujikawa v. Wattanasin*, 93 F.3d 1559, 1570, 39 U.S.P.Q. 2d 1895, 1904 (Fed. Cir. 1996). Nonetheless, the disclosure must convey with reasonable clarity to one skilled in the art that the inventor is in possession of the invention. *Vas-Cath, Inc. v. Mahurkar*, 935 F.2d 1555, 1563-4, 19 U.S.P.Q. 2d 1111, 1116-1117 (Fed. Cir. 1991). One skilled in the art, reading the original disclosure, must reasonably discern the limitation at issue in the claims. *Waldemar Link GmbH and Co. v. Osteonics Corp.*, 32 F.3d 556, 558, 31 U.S.P.Q. 2d 1855, 1857 (Fed. Cir. 1994).

#### “Substantially Coplanar”

With respect to the planes both being parallel and substantially coplanar, a plurality of spring windings can be parallel, of course. They cannot be perfectly coplanar, but if the spring is small enough (*i.e.*, annular), they can be “substantially” coplanar. Only “substantial” coplanarity is claimed. Since the plane does not require precise coplanarity but substantial coplanarity, the rejection should be reversed.

Claims 66-74 do not include the “substantially coplanar” language.

#### “Helical Coil”

The assertion that “flattened helical coil” lacks support is belied, for example, by Figure 1, showing a flattened helical coil, and Figure 10, showing a cross-section of a flattened helical coil. The illustrated coil is flattened at least in the direction of the length of the axis of symmetry where all the wraps of the coil are bunched together in a tight annular ring, as depicted.

The assertion (Final Rejection, p. 6) that “helical” is not used in the specification and “coil” (Specification at p. 7, lines 20-26) is used more analogously to “winding” is not true. The term “coil” is used to refer to the strands that are wound by wrapping them around a mandrel (Specification at p. 7, lines 10-13). There is no way to form a coil of strands by wrapping them around a mandrel without forming a helical coil.

Claims 67-69 do not include the flattened helical coil language.

“Wraps Back on Itself”

The claim language “the loop wraps back upon itself” and “turns back upon itself”, or “each of the loops wrapping back upon itself”, or “wire turned back upon itself” is clearly shown in the figures. Each of the loops must come back upon itself. The loops cannot be open since they clearly form a tight circular shape.

“Wraps back on itself” refers to wrapping wire up as around a mandrel. Initially when the first loop is completed by a 360° revolution, a portion of the wire wraps back upon the end of the wire (*i.e.*, wraps back upon itself). This process is repeated for each loop.

Therefore the rejection should be reversed.

“Closed Loop”

The Final Rejection (p. 6) suggests that the helically wrapped strands cannot form “closed loops”. When the strand circles back 360°, it closes a loop.

The Final Rejection distinguishes a closed ring as having no beginning or end. But all rings can be said to have no beginning or end. Therefore “closed” before “ring” is merely redundant.

“Closed” before “loop” explains that the loop closes upon itself by wrapping 360°.

“Closed loop” is not even used in claims 81 or 82.

**B. Are claims 65-73, 75-79, and 81-82 indefinite under 35 U.S.C. § 112, second paragraph as failing to particularly point out and distinctly claim the subject matter of the invention?**

A claim must set out and circumscribe a particular area with a reasonable degree of precision and particularity when read in light of the disclosure as it would be by the artisan. *In re Moore*, 439 F.2d 1232, 1235, 169 U.S.P.Q. 236, 238 (CCPA 1971). Acceptability of the claim language depends on whether one of ordinary skill in the art would understand what is claimed in light of the specification. *Seattle Box Co. v. Industrial Crating & Packing, Inc.*, 731 F.2d 818, 826, 221 U.S.P.Q. 568, 574 (Fed. Cir. 1984).

The § 112 rejection of claims 65 and 75-79 should be reversed since no claim requires

parallel and precise coplanarity but instead the claims only call for “substantial” coplanarity.

\* \* \*

Applicant respectfully requests that each of the final rejections be reversed and that the claims subject to this Appeal be allowed to issue.

Respectfully submitted,

Date: \_\_\_\_\_

  
\_\_\_\_\_  
Timothy N. Trop, Reg. No. 28,994  
TROP, PRUNER & HU, P.C.  
1616 S. Voss Road, Suite 750  
Houston, TX 77057  
713/468-8880 [Phone]  
713/468-8883 [Fax]

## CLAIMS APPENDIX

The claims on appeal are:

65. A prosthesis comprising:  
a tubular graft having a length, a pair of free ends opposed along the length of said graft, and a first diameter perpendicular to said length; and  
a deformable ring having a second diameter, said second diameter parallel to said first diameter, the ring formed of a bundle of windings of a strand of resilient metal wire, said windings connected together to form the ring, the windings wrapped one over the other such that a particular winding has substantially continuous contact with one or more other windings for a complete turn of the particular winding, each winding being a closed loop of a portion of said metal wire, each loop having substantially said second diameter, each loop lying substantially in a plane, the planes of said loops being parallel and substantially coplanar, the second diameter of said ring greater than the first diameter of the tubular graft, said ring secured to said graft adjacent one of said free ends, each of said loops constituting a length of a portion of said metal wire such that the loop wraps back upon itself, said loops defining a flattened helical coil wherein said loops that define the coil touch adjacent loops of the coil.

66. A prosthesis comprising:  
a tubular graft having a length, a pair of free ends opposed along the length of said graft, and a first diameter perpendicular to said length; and  
a bundle of radially overlapping windings formed of a single strand of resilient metal wire, a particular winding having substantially continuous contact with one or more other windings throughout a complete turn of said particular winding, a second diameter of said bundle of windings greater than the first diameter of said graft, said windings being concentric with said tubular graft and located adjacent one of said free ends, said bundle being a helical coil of a plurality of closed loops, each loop being a portion of a length of said wire wrapped upon itself, said loops being collapsed along an axis of said coil to form a flattened helical coil, said axis extending generally transverse to the diameters of said loops, each of said loops having

substantially the same diameter and each of said loops contacting at least one adjacent loop of said helical coil, said second diameter being parallel to said first diameter.

67. A prosthesis comprising:

a tubular graft having a length, a pair of free ends opposed along the length of said graft, and a first diameter perpendicular to said length; and

a ring located adjacent one of said free ends and coaxial therewith, said ring having a second diameter and comprising windings formed of a single strand of resilient metal wire, the second diameter of the ring substantially the same as a diameter of at least one of the windings, the windings wound one over the other and connected to form a bundle, the bundle of said windings having a substantially circular cross-section, each of said windings being a closed loop of a portion of said metal wire, said loop being substantially circular, having substantially the same diameter as said ring, contacting at least one adjacent loop, and turned back on itself to form a circular loop, said second diameter parallel to said first diameter, said ring comprising said windings and said graft being coaxial.

68. The prosthesis of claim 67 wherein the minimum bending diameter of said ring is less than that of a solid ring of the same dimensions.

69. The prosthesis of claim 65 wherein a portion of said tubular graft proximate said ring has a second diameter.

70. A prosthesis for being positioned in a blood vessel comprising:

a graft; and

an annular resilient element attached to said graft, said element comprising a bundle of concentric, radially overlapping windings formed of a strand of resilient wire, each winding in the form of a closed loop of a portion of the length of said resilient wire, each of said loops wrapping back upon itself, said loops collectively defining a flattened helical coil defining said annular resilient element, a diameter of the annular resilient element substantially the same as a diameter of at least one of said windings, said annular resilient element adapted to be folded about its diametric axis to assume a smaller cross-sectional configuration and adapted to engage the inside of a body passage in said folded configuration, and when said folded annular resilient

element is engaged with said body passage, said graft to extend along a length of a first blood vessel, a part of said graft adapted to be positioned past a point of an intersection of said first blood vessel and a second blood vessel so as not to occlude an opening to permit communication of said intersection, said folded annular resilient element defining a C-shaped configuration, said graft and said element being coaxial.

71. The prosthesis of claim 70 wherein a diameter of said graft is sized to be approximately the same as a diameter of a given blood vessel.

72. The prosthesis of claim 70 wherein said element has an undeformed diameter greater than the diameter of said graft.

73. The prosthesis of claim 70 wherein an undeformed diameter of said element is sized to be greater than a diameter of a given blood vessel.

75. A prosthesis for being positioned in a blood vessel comprising:  
an annular resilient element, said element comprising a bundle of concentric, radially overlapping windings formed of a strand of resilient metal wire, one of said windings in contact with another of said windings, said contact for a full turn of said one of said windings and said contact not limited to contact with the same another of said windings, a diameter of the annular element substantially the same as a diameter of at least one of said windings, said annular element adapted to be folded about its diametric axis to assume a smaller cross-sectional configuration, said folded element adapted to be situated in said blood vessel with an arcuate portion of said folded element engaged with said blood vessel;  
said annular resilient element being a helical coil made up of the plurality of parallel loops having substantially the same diameter and having a common axis, said loops being flattened upon one another so that adjacent loops are touching, substantially coplanar, and parallel; and  
a graft, said element attached to an end of said graft, a tip of each fold of said folded element to contact the graft, said graft having a length parallel to the common axis of said loop.

76. The prosthesis of claim 75 wherein said graft is adapted to extend along a length of a first blood vessel and a part of said graft is positionable past a point of an intersection of said first blood vessel and a second blood vessel so as not to occlude an opening to permit communication of said intersection.

77. The prosthesis of claim 75 wherein a diameter of said graft is approximately the same as a diameter of the blood vessel, in which said prosthesis is to be positioned.

78. The prosthesis of claim 75 wherein the unfolded diameter of said element is greater than the diameter of said graft.

79. The prosthesis of claim 75 wherein the unfolded diameter of said element is greater than a diameter of the blood vessel, in which said prosthesis is to be positioned.

81. A prosthesis for being positioned in a blood vessel comprising:  
a tubular graft having a length; and  
an annular resilient element attached to said graft, said element comprising a bundle of concentric, windings formed of a strand of resilient metal wire, said windings overlapping along radii of said annular resilient element, a diameter of the annular element substantially the same as a diameter of at least one of said windings, said annular element adapted to be folded about its diametric axis to assume a smaller cross-sectional configuration, said graft adapted to be positioned within a first blood vessel proximate to a second blood vessel such that the diametric axis of said element is proximate to an intersection of said first blood vessel and said second blood vessel and a part of said graft is to extend past said intersection so as not to occlude an opening and to permit communication with said intersection, only a part of both said graft and said annular resilient element to engage a portion of said first blood vessel located past said second blood vessel, said windings formed of a plurality of circular loops formed of a portion of said wire turned back on itself such that a plurality of adjacent loops are connected together to form a helical coil, said helical coil being flattened such that each of said loops touch another loop and each of said loops are substantially coplanar with each of said other loops and said loops having a common central axis, said element having a central axis parallel to the length of said graft.

82. A prosthesis comprising:  
a tubular graft having a length; and  
a deformable, annular, resilient element located near one end of said graft, said element comprising a bundle of windings formed of a strand of wire, said windings overlapping along radii of said annular resilient element, said bundle substantially circular in cross-section, wherein said cross-section can be taken at any point on a circumference of said element, a diameter of said element substantially the same as a diameter of at least one of said windings, said element adapted to be folded around its diametric axis and to resiliently engage a first human blood vessel in a C-shaped deformed configuration, a part of said C-shaped deformed element to resiliently engage said first human blood vessel past a point of intersection of said first blood vessel and a second blood vessel to permit communication of said intersection, each of said windings being a loop of a portion of a length of wire turned back on itself such that a plurality of adjacent loops are connected together defining a helical coil, said helical coil being flattened such that each of said loops touch another loop and each of said loops is substantially coplanar with each of said other loops and said loops have a common central axis, said element having a central axis parallel to the length of said graft.



**EVIDENCE APPENDIX**

None.

## **RELATED PROCEEDINGS APPENDIX**

*See* on the following pages:

Decision on Appeal No. 2001-1407, in the present case; and

Decision on Appeal No. 2003-1502, in 09/365,860, now US Patent No. 6,740,111, a continuation of the present case.

SLZ.000545



The opinion in support of the decision being entered today was not written for publication and is not binding precedent of the Board.

Paper No. 30

UNITED STATES PATENT AND TRADEMARK OFFICE

BEFORE THE BOARD OF PATENT APPEALS AND INTERFERENCES

Ex parte KARL-LUTZ LAUTERJUNG

Appeal No. 2001-1407  
Application No. 08/878,908

ON BRIEF

MAILED

SEP 13 2002

PAT. & T.M. OFFICE  
BOARD OF PATENT APPEALS  
AND INTERFERENCES

Before ABRAMS, FRANKFORT, and NASE, Administrative Patent Judges.  
ABRAMS, Administrative Patent Judge.

DECISION ON APPEAL

This is a decision on appeal from the examiner's final rejection of claims 21-25, 28 and 63-65. Claims 32, 33 and 36 have been allowed, and the remaining claims have been canceled.

We AFFIRM-IN-PART.

RECEIVED  
SEP 17 2002

Trop, Pruner, & Hu, P.C.

DOCKET INFORMATION

Base Rate: 9-13-02

Due Date: 10-13-02

Action: Request for Reconsideration

11-12-02 Appeal to Court of Appeals

- Docket
- Pat. App
- Excel
- Abst./Title Pg
- Access
- Draw. [I/F]

BACKGROUND

The appellant's invention relates to a vascular prosthesis. An understanding of the invention can be derived from a reading of exemplary claim 21, which appears in the appendix to the appellant's Brief.

The prior art references of record relied upon by the examiner in rejecting the appealed claims are:

Kwan-Gett	5,151,105	Sep. 29, 1992
Robinson <u>et al.</u> (Robinson)	5,733,325	Mar. 31, 1998
International Patent Application (Lazarus)	WO 89/08433	Sep. 21, 1989

Claims 21-25 and 28 stand rejected under 35 U.S.C. § 102(b) as being anticipated by Lazarus.

Claims 21-25 and 28 stand rejected under 35 U.S.C. § 102(e) as being anticipated by Robinson.

Claims 63-65 stand rejected under 35 U.S.C. § 102(b) as being anticipated by Kwan-Gett.

Rather than reiterate the conflicting viewpoints advanced by the examiner and the appellant regarding the above-noted rejections, we make reference to the Answer (Paper No. 25) and the Supplemental Answer (Paper No. 29) for the examiner's complete reasoning in support of the rejections, and to the Brief (Paper No. 24) and the Reply Brief (Paper No. 26) for the appellant's arguments thereagainst.

OPINION

In reaching our decision in this appeal, we have given careful consideration to the appellant's specification and claims, to the applied prior art references, and to the respective positions articulated by the appellant and the examiner. As a consequence of our review, we make the determinations which follow.

All of the rejections are under 35 U.S.C. § 102. The guidance provided by our reviewing court with regard to the matter of anticipation is as follows: Anticipation is established only when a single prior art reference discloses, either expressly or under the principles of inherency, each and every element of the claimed invention. See In re Paulsen, 30 F.3d 1475, 1480-1481, 31 USPQ2d 1671, 1675 (Fed. Cir. 1994) and In re Spada, 911 F.2d 705, 708, 15 USPQ2d 1655, 1657 (Fed. Cir. 1990). Anticipation by a prior art reference does not require either the inventive concept of the claimed subject matter or recognition of inherent properties that may be possessed by the reference. See Verdegaal Brothers Inc. v. Union Oil Co. of California, 814 F.2d 628, 633, 2 USPQ2d 1051, 1054 (Fed. Cir. 1987). The law of anticipation does not require that the reference teach what the applicant is claiming, but only that the claim on appeal "read on" something disclosed in the reference, *i.e.*, all limitations of the claim are found in the reference. See Kalman v. Kimberly-Clark Corp., 713 F.2d 760, 772, 218 USPQ 781, 789 (Fed. Cir. 1983), *cert. denied*, 465 U.S. 1026 (1984).

*The Rejection On The Basis Of Lazarus*

We agree with the examiner that claim 21 is anticipated by Lazarus, which is directed to an artificial graft, on the basis of the reasoning set forth by the examiner on pages 2 and 3 of the Supplemental Examiner's Answer (Paper No. 29). We emphasize that while the Lazarus springs may be formed and may function in a manner different from the springs of the appellant's invention, the language of claim 21 reads on the embodiment shown in Figure 3, which is all that is necessary to form the basis for anticipation. The appellant's only argument with respect to this rejection of claim 21 is that the Lazarus springs are not "folded," a conclusion with which we do not agree. The common applicable definition of "folded" is "to become doubled or pleated."<sup>1</sup> While they may have been bent to do so, the Lazarus springs nevertheless are "folded" at 62.

This rejection of claim 21 is sustained.

The appellant has chosen to group claims 24, 25 and 28 with claim 21 (Brief, page 7), and thus they fall therewith.

Claim 22 states that "said second pair of loops are arranged to avoid occlusion of the renal arteries when said prosthesis is positioned in the abdominal aorta." We agree with the examiner that this is a statement of intended use, inasmuch as it does not add a structural limitation to the prosthesis. Moreover, the claim does not, as the appellant apparently believes, require that the ends of the graft and the springs describe a

---

<sup>1</sup>See, for example, Webster's New Collegiate Dictionary, 1973, page 445.

configuration that has loop-like void areas such as are shown in Figure 5; it merely recites that the prosthesis be so positioned as to "avoid occlusion" of the renal arteries, which in our view can be accomplished by proper positioning of the Lazarus prosthesis. We therefore will sustain this rejection of claim 22.

Claim 23 adds to claim 21 the requirement that the diameter of the graft be less than the unfolded diameter of one of the springs. Lazarus teaches that the diameter of the unfolded staples (springs), that is, the diameter when in their operating configuration, "will be generally the same as" the diameter of the graft (page 8, lines 10 and 11). This being the case, the diameter of the graft is not less than that of the unfolded springs, and Lazarus does not anticipate the limitation recited in claim 23. We will not sustain this rejection.

*The Rejection On The Basis Of Robinson*

This rejection also applies to claims 21-25 and 28. We agree with the examiner that claim 21 is anticipated by Robinson for the reasons explained on pages 4 and 5 of the Supplemental Answer, noting that the definition of "folded" is met by the Robinson springs at 37 of Figure 4.

This rejection of claims 22, 24, 25 and 28 is sustained on the same bases as were set forth above with regard to the rejection on the basis of Lazarus.

Robinson teaches that the diameter of the unfolded (freely expanded) spring (anchor 30) be greater than that of the graft (column 8, lines 13-17), the feature which is added to claim 21 by claim 23. This rejection of claim 23 therefore is sustained.

*The Rejection On The Basis Of Kwan-Gett*

Independent claims 63 and 65, and dependent claim 64, stand rejected as being anticipated by Kwan-Gett. Both of the independent claims require that there be a ring "comprising a bundle of overlapping windings formed of a strand of resilient wire." The examiner has taken the position that this reads on Kwan-Gett's circular stents 18 and 20, which "preferably comprise lengths of thin, flat spring material . . . that are concentrically wound into torsion springs, similar to a watch or clock spring" (column 5, lines 20-24), because the appellant has not provided a special definition of wire which would exclude such an element. We do not agree that the Kwan-Gett lengths of flat spring material fall within the definition of "wire,"<sup>2</sup> and we will not sustain the rejection of claims 63-65.

CONCLUSION

The rejection of claims 21, 22, 24, 25 and 28 as being anticipated by Lazarus is sustained.

The rejection of claim 23 as being anticipated by Lazarus is not sustained.

---

<sup>2</sup>Metal in the form of a flexible thread or slender rod. See, for example, Webster's New Collegiate Dictionary, 1973, page 1345.





Appeal No. 2001-1407  
Application No. 08/878,908

Page 8

TIMOTHY N. TROP  
TROP, PRUNER & HU, P.C.  
8554 KATY FREEWAY, SUITE 100  
HOUSTON, TX 77024



VAS.0002CIUS

The opinion in support of the decision being entered today was not written for publication and is not binding precedent of the Board.

Paper No. 20

UNITED STATES PATENT AND TRADEMARK OFFICE

BEFORE THE BOARD OF PATENT APPEALS AND INTERFERENCES

Ex parte KARL-LUTZ LAUTERJUNG

Appeal No. 2003-1502  
Application No. 09/365,860

ON BRIEF

MAILED

SEP 29 2003

PAT. & T.M. OFFICE  
BOARD OF PATENT APPEALS  
AND INTERFERENCES

Before ABRAMS, FRANKFORT, and NASE, Administrative Patent Judges.  
ABRAMS, Administrative Patent Judge.

DECISION ON APPEAL

This is a decision on appeal from the examiner's final rejection of claims 1, 2, 5, 10 and 52, which are all the claims remaining in the application.

We REVERSE.

RECEIVED  
OCT 02 2003

Trop, Pruner, & Hu, P.C.

DOCKET INFORMATION

Base Rate: 9-29-03  
Due Date: 12-27-03  
Action: Status Inquiry  
(action from examiner)

- Docket
- Pat. App
- Excel
- Abst./Title Pg
- Access
- Draw. (I/F)

BACKGROUND

The appellant's invention relates to a device for retaining a prosthesis within a body passage. An understanding of the invention can be derived from a reading of exemplary claim 1, which has been reproduced below.

The prior art references of record relied upon by the examiner in rejecting the appealed claims are:

Kwan-Gett	5,151,105 ✓	Sep. 29, 1992
Inoue (Inoue '671)	5,676,671	Oct. 14, 1997
Inoue (Inoue '179)	5,976,179 ✓	Nov. 2, 1999

Claims 1, 2, 5 and 10 stand rejected under 35 U.S.C. § 102(e) as being anticipated by Inoue '179 or, in the alternative, under 35 U.S.C. § 103(a) as being unpatentable over Inoue '179.

Claim 52 stands rejected under 35 U.S.C. § 102(e) as being anticipated by Inoue '671 or, in the alternative, under 35 U.S.C. § 103(a) as being unpatentable over Inoue '671.

Claims 1 and 2 stand rejected under 35 U.S.C. § 102(b) as being anticipated by Kwan-Gett.

Rather than reiterate the conflicting viewpoints advanced by the examiner and the appellant regarding the above-noted rejections, we make reference to the Answer (Paper No. 16) for the examiner's complete reasoning in support of the rejections, and

to the Brief (Paper No. 15) and Reply Brief (Paper No. 17) for the appellant's arguments thereagainst.

### OPINION

In reaching our decision in this appeal, we have given careful consideration to the appellant's specification and claims, to the applied prior art references, and to the respective positions articulated by the appellant and the examiner. As a consequence of our review, we make the determinations which follow.

#### *Representative Claim 1*

A device for retaining a prosthesis within a body passage comprising an annular, resilient element, wherein said element is formed by overlapping a plurality of windings of wire radially on top of one another around a common core and connecting the two windings together to form a bundle, said wire being sized to decrease the minimum bending diameter of said element.

#### *The Section 102 Rejection Based Upon Inoue '179*

Claim 1 stands rejected as being anticipated<sup>1</sup> by Inoue '179. In arriving at this conclusion, the examiner has taken the position that "the multiple rings [of Inoue '179] are windings of wire to the extent required" (Answer, page 4), which we assume means the examiner considers the rings disclosed in Inoue '179 to constitute "windings." The

---

<sup>1</sup>Anticipation is established only when a single prior art reference discloses, expressly or under the principles of inherency, each and every element of the claimed invention. See, for example, RCA Corp. v. Applied Digital Data Systems, Inc., 730 F.2d 1440, 1444, 221 USPQ 385, 388 (Fed. Cir. 1984).

appellant argues that this is an erroneous conclusion in view of the common definition of "winding" as well as the explanation of the invention in the specification.

There appears to be no dispute that a "winding" is a turn of wire or rope wound around an object, a spiral, for the appellant has so asserted on page 13 of the specification and the examiner has offered such a definition on page 7 of the Answer. The appellant's specification explains the construction of the clamping rings in a manner that conforms with this definition, for it describes them as being formed by "wrapping a single length of wire around the mandrel" to form a number of coils (page 7). Based upon this evidence, it is our opinion that the designation of a wire as a "winding" in the present case would be interpreted by one of ordinary skill in the art to be a structural limitation requiring that the annular wire ring be formed by winding a wire in a spiral manner about an object such as a core. In this regard, the appellant argues that the broadest reasonable interpretation of a winding does not include a closed ring, which is what he believes is disclosed in Inoue '179.

Inoue '179 discloses a collapsible prosthesis having, as shown in Figure 36, to which the examiner refers, an "end wire ring" W1 comprising four wire elements W2 bound together. Neither the manner in which the wire elements are manufactured nor details of their construction are explained, other than to state that they preferably are made of nickel-titanium alloy and have sufficient flexibility and strength so there is little

danger of them injuring the blood vessel into which the prosthesis is inserted (column 21). The wire elements are not described as being "windings," nor can it be determined from the drawings that they are anything other than closed annular rings.

We therefore find ourselves in agreement with the appellant that the examiner's determination that the wire elements disclosed in Inoue '179 are "windings" is not supported by the evidence. This being the case, it is our conclusion that Inoue '179 does not disclose or teach an annular element formed of "a plurality of windings of wire" and thus does not anticipate the subject matter recited in claim 1 and we therefore will not sustain the rejection. It follows that we also will not sustain the like rejection of claims 2, 5 and 10, which depend from claim 1.

*The Section 103 Rejection Based Upon Inoue '197*

As an alternative, the examiner rejects claims 1, 2, 5 and 10 as being obvious<sup>2</sup> in view of Inoue '179. As we understand this rejection, it is the examiner's position that if the rings of Inoue '179 are not considered to constitute "windings," one of ordinary skill

---

<sup>2</sup>The test for obviousness is what the teachings of the applied prior art would have suggested to one of ordinary skill in the art. See, for example, In re Keller, 642 F.2d 413, 425, 208 USPQ 871, 881 (CCPA 1981). In establishing a prima facie case of obviousness, it is incumbent upon the examiner to provide a reason why one of ordinary skill in the art would have been led to modify a prior art reference or to combine reference teachings to arrive at the claimed invention. See Ex parte Clapp, 227 USPQ 972, 973 (Bd. Pat. App. & Int. 1985). To this end, the requisite motivation must stem from some teaching, suggestion or inference in the prior art as a whole or from the knowledge generally available to one of ordinary skill in the art and not from the appellant's disclosure. See, for example, Uniroyal, Inc. v. Rudkin-Wiley Corp., 837 F.2d 1044, 1052, 5 USPQ2d 1434, 1439 (Fed. Cir.), cert. denied, 488 U.S. 825 (1988).

in the art would have found it obvious to modify the disclosed device by replacing the closed ring wire elements with "windings," as such are defined above (Answer, page 4). From his remarks, it would appear that the examiner is contending that the two forms of wire ring elements are considered to be equivalents in the art, but no evidence in support of this conclusion has been provided. Nor has the examiner set forth a reason why one of ordinary skill in the art would have been motivated to make the substitution of elements proposed in the rejection.

In the absence of a teaching, suggestion or incentive which would have led one of ordinary skill in the art to make the proposed modification, it is our view that of Inoue '197 fails to establish a prima facie case of obviousness with regard to the subject matter recited in claim 1, and this rejection of claims 1, 2, 5 and 10 cannot be sustained.

*The Section 102 Rejection Based Upon Inoue '671*

This rejection applies to claim 52, which also requires that the annular resilient element be "formed from a plurality of windings of wire." The examiner has taken the position that this reference teaches the windings "to the extent required," and refers to Figures 2, 16, 18, 19 and 23, as well as column 7, line 40 to column 16, line 49, as



providing the basis for this conclusion.<sup>3</sup> In our opinion, Inoue '671 fails to anticipate the claimed subject matter for the same reasons expressed above with regard to the Section 102 rejection based upon Inoue '179, and this rejection is not sustained.

*The Section 103 Rejection Based Upon Inoue '671*

This is an alternative to the rejection of claim 52 under Section 102. The examiner here poses the same reasoning regarding the "windings" as was presented with regard to the Section 103 rejection of claim 1 et al. over Inoue '179, that is, it would have been obvious to modify Inoue '671 by replacing the disclosed wire elements with "windings." For the reasons expressed above in the discussion of the cited rejection of claim 1, we also will not sustain this rejection of claim 52.

*The Section 102 Rejection Based Upon Kwan-Gett*

Claims 1 and 2 stand rejected as being anticipated by Kwan-Gett. The examiner has taken the position that the "windings of wire" recited in claim 1 read on Kwan-Gett's circular stents 18 and 20, which "preferably comprise lengths of thin, flat spring material . . . that are concentrically wound into torsion springs, similar to a watch or clock spring" (column 5, lines 20-24). We do not agree that the Kwan-Gett lengths of flat spring

---

<sup>3</sup>We note in passing that the examiner has not directed us to any specific passages in the text of this reference which might support his position, but merely refers us to five of the thirty-three figures in the drawings, and ten of the twelve columns of the specification that are directed to describing the invention.



Appeal No. 2003-1502  
Application No. 09/365,860

Page 9

TIMOTHY N. TROP  
TROP, PRUNER, HU & MILES, P.C.  
8554 KATY FREEWAY  
SUITE 100  
HOUSTON, TX 77024